

# ECLISSE SYNTESIS® LUCE SINGLE

SOLID WALL

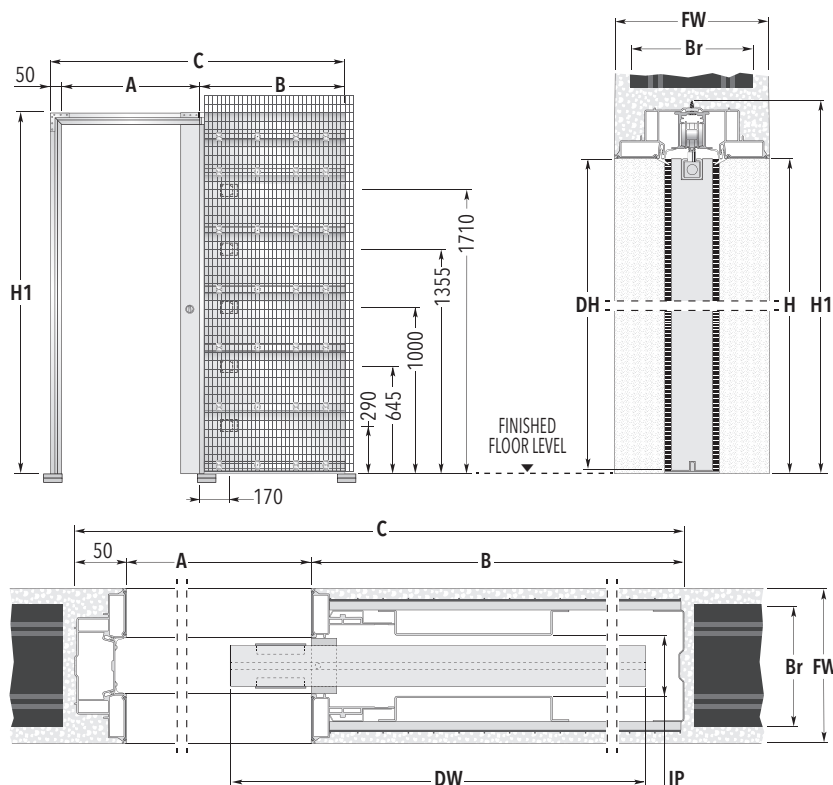

## WARNING

Door panels for ECLISSE SYNTESIS® FLUSH sliding pocket door systems must be milled along the upper and lower profiles, as shown below (milling not required on glass doors).

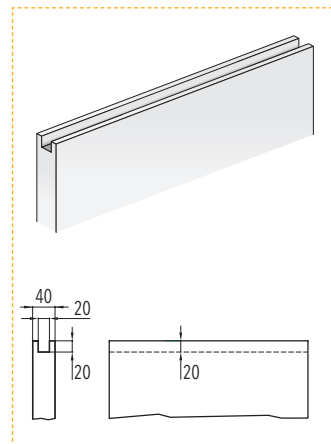

### SYSTEMS FOR SINGLE DOOR - Measures related to Italian standards, other dimensions available

PASSAGE SIZE <b>A x H</b>	OVERALL DIMENSIONS		DOOR PANEL*	
	<b>B</b>	<b>C x H1</b>	<b>DW</b>	<b>DH</b>
600 x 2000/2100	750	1393 x 2060/2160	615 ÷ 635	1992/2092
700 x 2000/2100	850	1593 x 2060/2160	715 ÷ 735	1992/2092
800 x 2000/2100	950	1793 x 2060/2160	815 ÷ 835	1992/2092
900 x 2000/2100	1050	1993 x 2060/2160	915 ÷ 935	1992/2092
1000 x 2000/2100	1150	2193 x 2060/2160	1015 ÷ 1035	1992/2092
FINISHED WALL = <b>FW</b>		BRICKS = <b>Br</b>	INTERNAL PASSAGE = <b>IP</b>	
<b>150</b> →		120	54	

Dimensions are given in mm

### NON-STANDARD SIZES

- ▶ Passage width  
600 ÷ 1300 mm
- ▶ Passage height  
1000 ÷ 2700 mm
- ▶ Half sizes require  
bespoke door panels  
(e.g. A=650 mm).

### NOTES

- ▶ Passage width A is reduced by 7 mm.
- ▶ For electrical boxes, only standard positions are possible.
- ▶ Arrangements for electrical boxes are provided as standard on both sides of each pocket.
- ▶ Max. electrical box depth 40 mm (2 boxes are supplied).
- ▶ Max. door thickness 40 mm (including any glass holder for glazed door).
- ▶ Max. door weight 100 kg (150 kg on request).
- ▶ Due to production characteristics of the system and for safety reasons, ECLISSE recommends the door protrudes by 80 mm.
- ▶ If needed, the adjustable door stop allows to modify the real passage size.
- ▶ For the door to disappear completely, milling is required.
- ▶ The milling for the door guide must have the following dimensions: 7x15 mm.
- ▶ Install at finished floor level.
- \* Listed measures refers to wooden door panels only.

### ACCESSORIES

- ▶ ECLISSE BIAS®
- ▶ ECLISSE BIAS® DS
- ▶ ECLISSE PUSH&PULL S
- ▶ Anti-warp profile
- ▶ ECLISSE SYNTESIS® BASEBOARD